



UPGRADE KIT: Contains a new door operator motor, SmarTRAQ drive unit and appropriate mounting hardware.

- How many upgrade kits do you need? _____
- Existing door operator manufacturer: _____ Model: _____
- Fill out the job, contractor, and shipping information below and fax this page to MCE at (916) 638 1418

IF YOU NEED ADDITIONAL COMPONENTS, complete and submit all three pages of this survey form.

CAR SIDE

CAR SIDE

	QTY		COST
Base Door Operator.....	_____	@ \$1578 =	_____
2 Spd Drv Arm Lnk (SSL Only)	_____	@ \$38 =	_____
Track,Hanger,Rollers, Header...	_____	per quote =	_____
Clutch.....	_____	@ \$109 =	_____
Clutch w/Restrictor.....	_____	@ \$215 =	_____
Mounting Plate.....	_____	@ \$22.50=	_____
Slave Door Drive Assembly.....	_____	@ \$30.50 =	_____
Mounting Plate.....	_____	@ \$8 =	_____

	QTY		COST
Gate Switch.....	_____	@ \$43 =	_____
IR Detector, Janus Pana 40.....	_____	@ \$381 =	_____
Door Position Monitor Switch.....	_____	@ \$56 =	_____

DPM required: ANSI A17.1 1998
& 2000, and CSA.

HATCH SIDE

HATCH SIDE

	QTY		COST
Track,Hanger w/ roller assembly, closer, and interlock	_____	per quote =	_____
Hall Door Interlock Assembly.....	_____	@ \$70 =	_____
Pick Up Roller Mounting Plate...	_____	@ \$8 =	_____

	QTY		COST
Sngl Spd Door Closer. Sill, w/spring	_____	@ \$61 =	_____
2-spd Door Closer, Sill, w/spring....	_____	@ \$77 =	_____
2-spd Door Closer, Sill.....	_____	@ \$69 =	_____
Spirator Closer.....	_____	@ \$39 =	_____

Select door operator mounting orientation and (if center parting) car door clutch location

SIDE SLIDE

OPERATOR

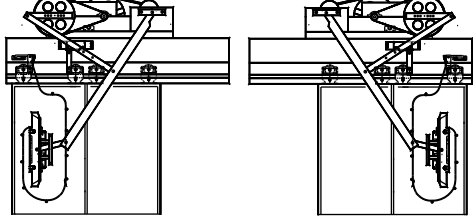

LEFT HAND

RIGHT HAND

CENTER PART

PICK OPERATOR ORIENTATION

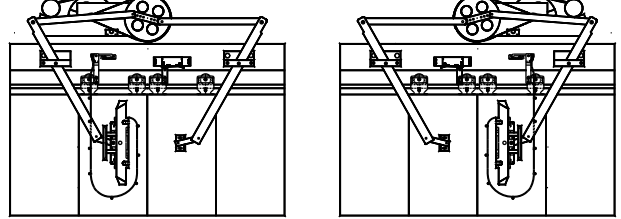

PICK DOOR FOR CLUTCH LOCATION

VIEW FROM HALL

Job name: _____
 Customer Job #: _____
 Purchase order #: _____
 Requested ship date: _____
 Todays date: _____
 Ship To: _____
 Contact Name: _____
 Phone #: _____ Fax #: _____
 Street Address: _____
 City: _____ State: _____ Zip: _____
 24-hour notice needed? Lift gate truck needed?

Contractor: _____
 Contact Name: _____
 Phone #: _____ Fax #: _____
 Street Address: _____
 City: _____ State: _____ Zip: _____
 E Mail Address: _____
 FORM COMPLETED BY:
 Name: _____
 Company: _____
 Phone #: _____ Fax #: _____
 Signature: _____
 E Mail Address: _____

If you are ordering car-mounted products beyond the upgrade kit, please complete this page.

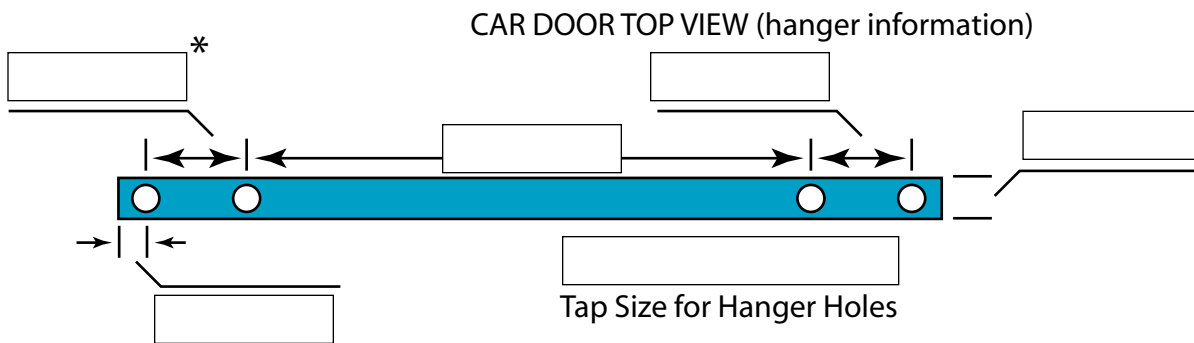
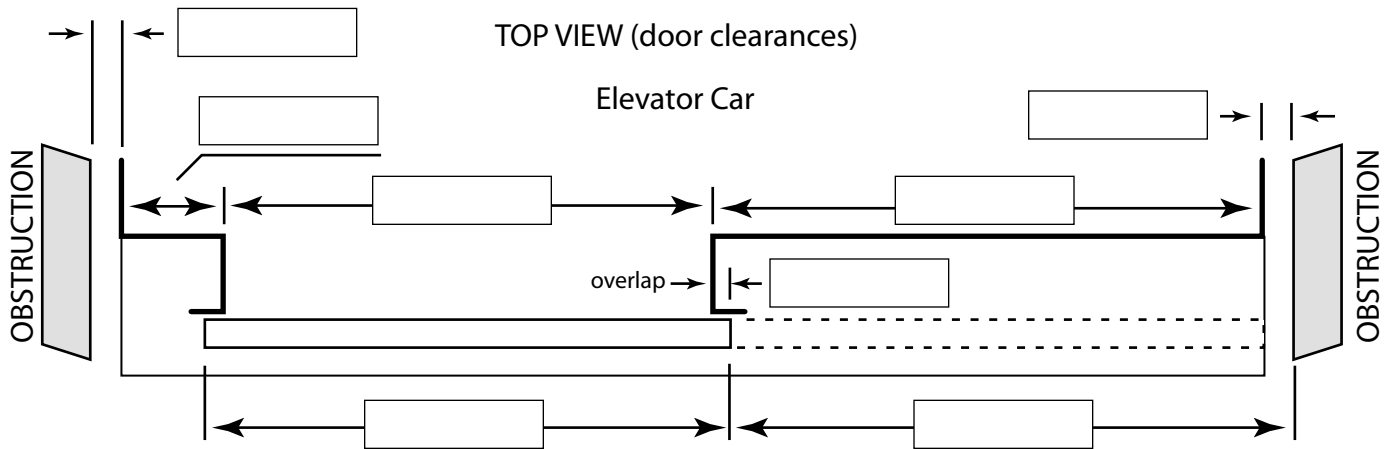

* Standard center to center dimension for MCE door hangers is 4 1/8". An adapter is used to accommodate other center to center dimensions. If adapters are used, the door track must be raised 1/2" to compensate.

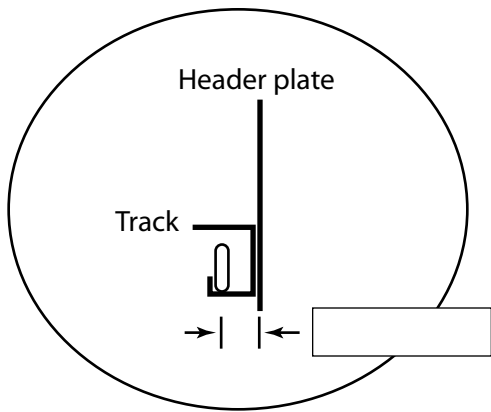

FROM EXISTING INSTALLATION
 If applicable

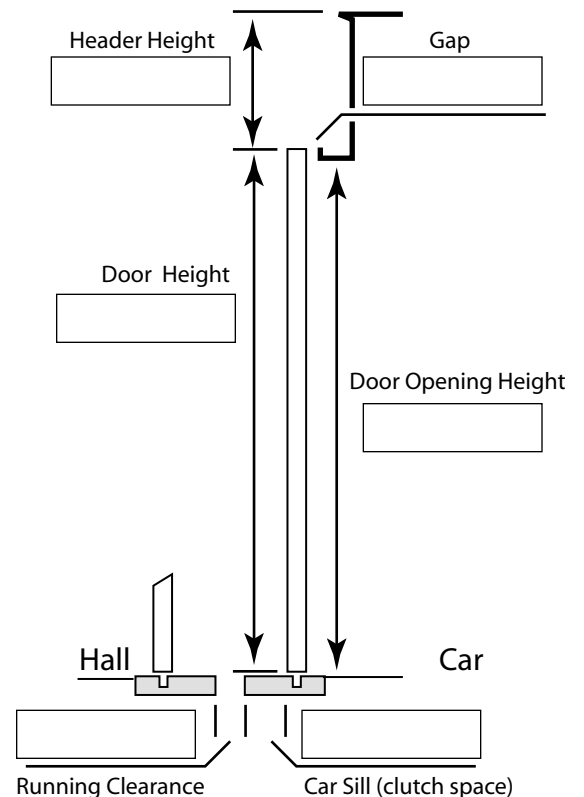

Job Name: _____

If you are ordering hall-mounted products, please complete this page.

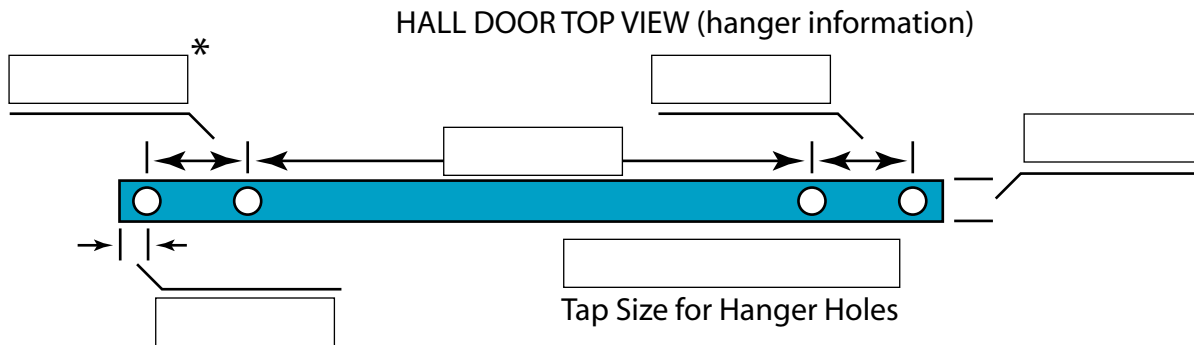
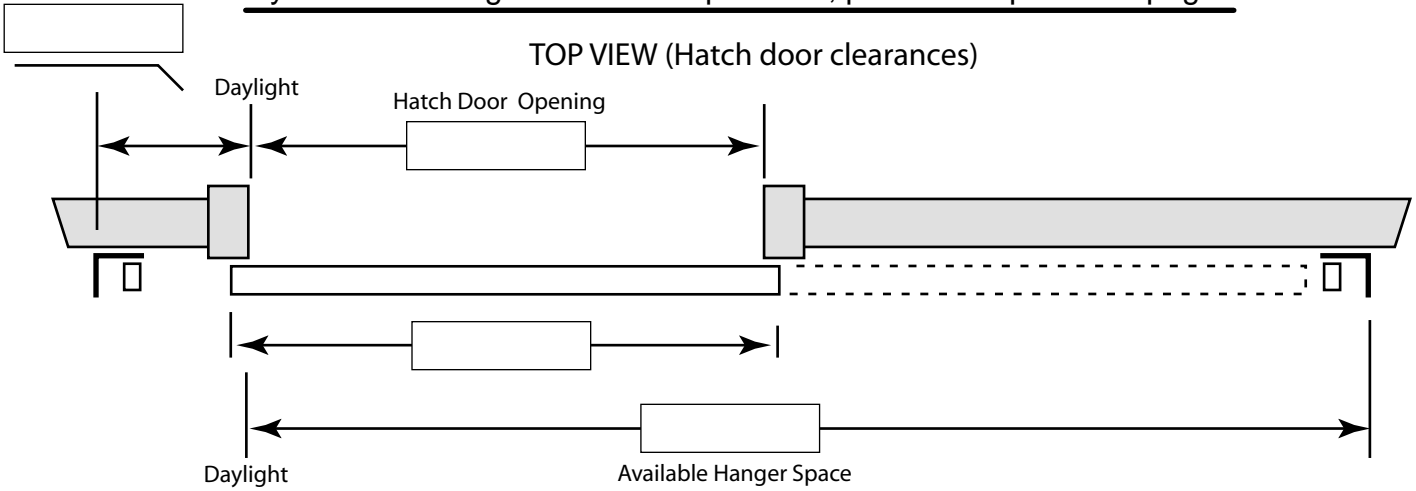

* Standard center to center dimension for MCE door hangers is 4 1/8". An adapter is used to accommodate other center to center dimensions. If adapters are used, the door track must be raised 1/2" to compensate.

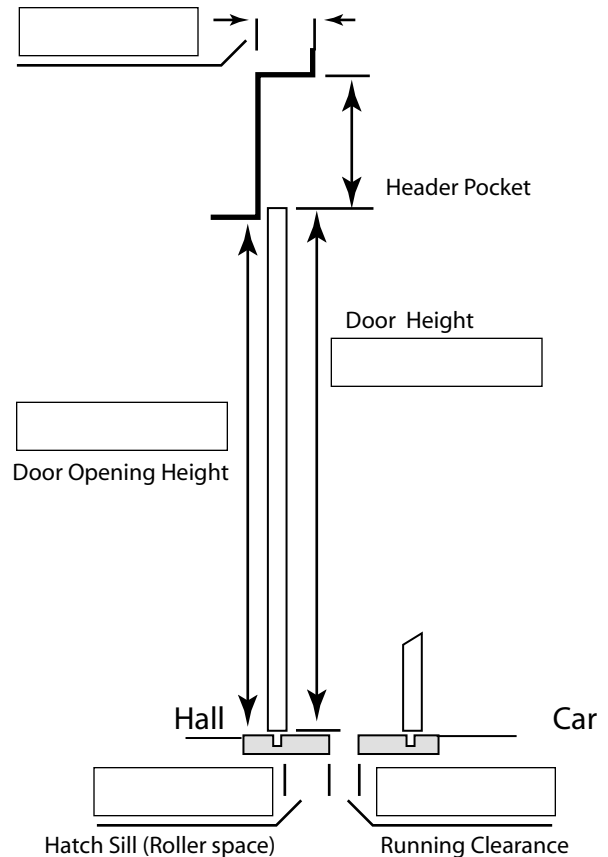
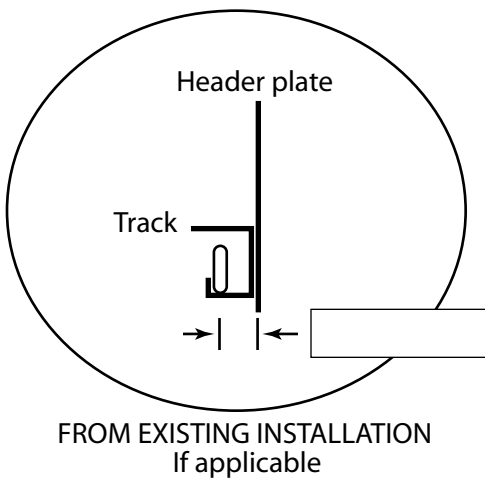

Job Name: _____